

L
2.0
3.0
4.0

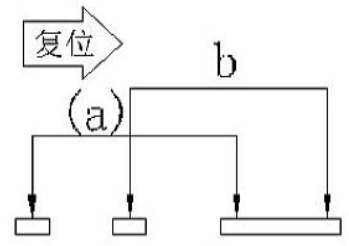

Circuit Diagram

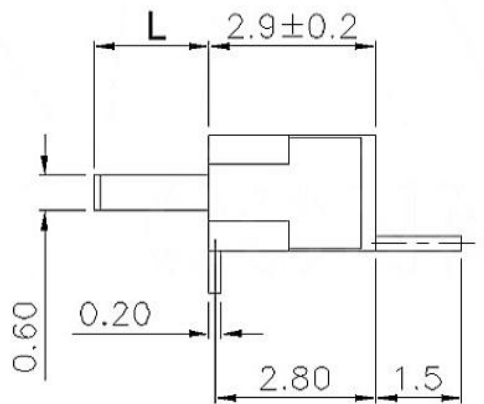
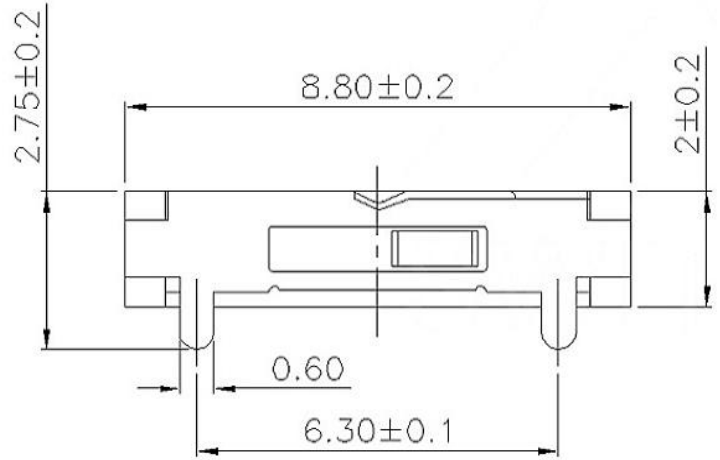

NOTE:
 Rating: DC 12V 50mA
 Operating Force: 200±100gf
 Lifetime: 10,000 Cycles

注: "*"表示关键尺寸(6个)

8					TOLERANCE				
7	STEEL BALL	STEEL	1	NATURAL	UNLESS SPECIFIED				
6	SPRING	STEEL WIRE	1	NATURAL	WITHIN	A	2012-10-26	初版	
5	CONTACT CLIP	PBS STRIP	2	Ag PLATED	OVER	ISSUE	DATE	DESCRIPTIONS OF REVISION	APPD.
4	TERMINAL	BRASS STRIP	8	Ag PLATED	TITLE : SLIDE SWITCH			UNIT : mm	DRWG NO.:
3	BASE	PHENOLIC RESIN	1	NATURAL	MODEL:			SCALE: 3:1	DWN.
2	FRAME	STEEL STRIP	1	Ni PLATED	东莞市高迪电子有限公司 DONGGUAN GAODI ELECTRONICS CO., LTD.				2012-10-26
1	KNOB	POM	1	BLACK				CHK'D	
NO.	PARTS	MATERIALS	Q'TY	FINISH				APPD.	